

Project Name:	
Location:	
Item:	Qty.:
Model:	

## Sandwich Units

- ▶ MXCR29S
- ▶ MXCR48S
- ▶ MXCR60S



Model MXCR29S



Model MXCR48S



Model MXCR60S

## FEATURES

- Stainless steel exterior
- Coated aluminum interior
- CFC Free Polyurethane insulated walls and doors
- Standard recessed door handles
- Adjustable, heavy-duty wire shelves, each unit comes with two per section/doors
- Four casters (2 locking, 2 non-locking)
- Stainless steel, stain resistant louver distributes air evenly through the unit
- Door width: 237/8"
- Efficient cooling system (two fans)
- Uses R-134a refrigerant
- Forced-air refrigeration
- Self-contained
- Temperature Range: Sandwich Prep Tables 33° to 41°F (1° to 5°C)



Specifications subject to change without notice.

Approvals:

## Sandwich Units

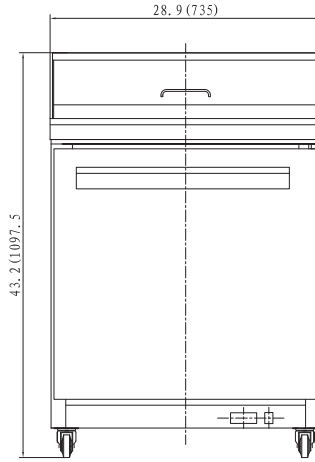

Model MXCR29S

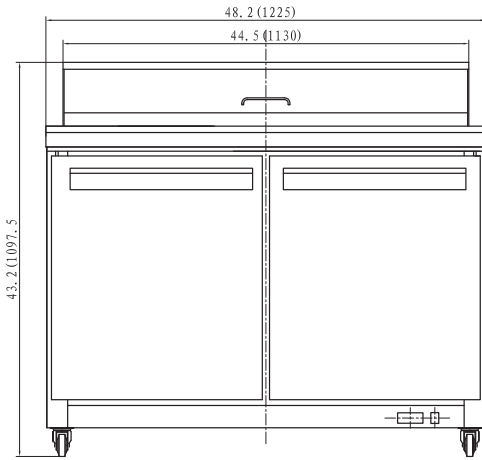

Model MXCR48S

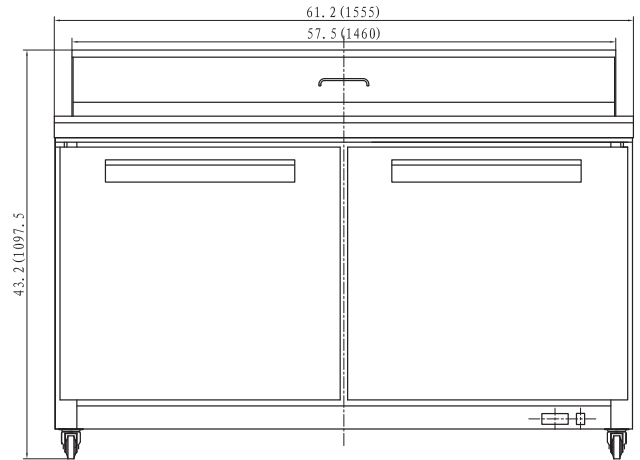

Model MXCR60S

### Dimensional Data

Model	Dim (WxDxH")	Capacity	Hp	Temp	Doors	Weight	Watts	Pans (1/6)	NEMA Plug (115/60/1 Only)
MXCR29S	29 x 30 x 43 (735x760x1097mm)	7 Cu Ft	3/8	28° to 39°	1	276 LB 125 KG	575	8	5-15P
MXCR48S	48 x 30 x 43 (1225x760x1097mm)	12 Cu Ft	1/2	28° to 39°	2	313 LB 142 KG	805	12	5-15P
MXCR60S	61 x 30 x 43 (1555x760x1097mm)	15.5 Cu Ft	1/2	28° to 39°	2	362 LB 164 KG	862	16	5-15P